

<b>HEIMANN Sensor GmbH</b>		<b>Product Specification: Low Heat Shock Thermopile Sensor HMS P11 F5.5</b>
Author(s): E. Kersting	Rev.: R 01 / 13.12.2019	Page 1 of 7

**Specification**  
**Low Heat Shock Thermopile Sensor**  
**HMS P11 F5.5**  
*Part No. 1268*

**R 01**

Author(s):

E. Kersting

**Revision History**

Version	Date	Remarks
R 01	13.12.2019	Revison 1

## TABLE OF CONTENTS

<b>1. Purpose, Scope</b> .....	<b>2</b>
<b>2. Absolute Maximum Ratings</b> .....	<b>2</b>
<b>3. General and Electrical Parameter Thermopile</b> .....	<b>2</b>
<b>4. General and Electrical Parameter Thermistor</b> .....	<b>3</b>
<b>5. Filter Characteristics</b> .....	<b>4</b>
<b>6. Drawing and Pin Assignment</b> .....	<b>6</b>
<b>7. General Directions for Further Processing</b> .....	<b>7</b>
<b>8. Liability</b> .....	<b>7</b>

### 1. Purpose, Scope

The new thermopile infrared sensor from Heimann Sensor, comprising a new type CMOS compatible sensor chip plus a thermistor reference chip, features good sensitivity, small temperature coefficient of sensitivity as well as high reproducibility and reliability.

The sensor was specially tailored to be exceptionally heat shock resilient and meets the requirements of the European Union RoHS (Regulation of Hazardous Substances) Directive.

The sensor will be available in standard transistor outline packages in different sizes, equipped with an IR transmitting filter window (transmission curve as shown below).

### 2. Absolute Maximum Ratings

<i>Parameter</i>	<i>Symbol</i>	<i>Limits</i>			<i>Units</i>	<i>Conditions</i>
		<i>Min</i>	<i>Typ.</i>	<i>Max</i>		
storage temperature *		-40		100	°C	
operating temperature		-20		100	°C	

\* ... see also §7

### 3. General and Electrical Parameter Thermopile

<i>Parameter</i>	<i>Symbol</i>	<i>Limits</i>			<i>Units</i>	<i>Conditions</i>
		<i>Min</i>	<i>Typ.</i>	<i>Max</i>		
element size			0.6*0.6		mm <sup>2</sup>	absorbing area
resistance	R <sub>TS</sub>	56	86	116	kΩ	-40°C to 100°C
voltage sensitivity	S <sub>V</sub>	37	53	69	V/W	filter F5.5, 100°C, 4.5 Hz
time constant	τ		6	10	ms	
noise voltage	V <sub>RMS</sub>		38		nV/√Hz	r.m.s., 25°C
detectivity	D*		8.5*10 <sup>7</sup>		cm√Hz/W	filter F5.5, 100°C, 4.5 Hz
insulation resistance	R <sub>iso</sub>	5			GΩ	10V, 25°C, 60% r.h., between

						pin 1 or 3 and 4 (ground)
--	--	--	--	--	--	---------------------------

#### 4. General and Electrical Parameter Thermistor

Type	Thermistor 100kΩ					
Parameter	Symbol	Limits			Units	Conditions
		Min	Typ.	Max		
resistance	R <sub>TH</sub>	95	100	105	kΩ	25°C
BETA-value	β	3900	3940	3980	K	25°C/50°C

T / °C	Rth_min / Ohm	Rth_nom / Ohm	Rth_max / Ohm
-30	1557900	1655000	1753100
-25	1163320	1234000	1306680
-20	875826	928700	981974
-15	665010	704500	744190
-10	508730	538500	568370
-5	392108	414600	437292
0	304466	321700	338934
5	238072	251400	264728
10	187444	197800	208056
15	148568	156600	164632
20	118404	124800	131096
25	95000	100000	105000
30	76537	80630	84713
35	62032	65380	68738
40	50543	53310	56077
45	41386	43680	45984
50	34070	35980	37890
55	28174	29770	31366
60	23405	24750	26095
65	19536	20670	21804
70	16383	17340	18297
75	13788	14600	15422
80	11653	12350	13047
85	9890	10480	11080
90	8421	8930	9444
95	7197	7635	8076
100	6172	6551	6935

**5. Filter Characteristics**

Filter F5.5					
Parameter	Limits			Units	Conditions
	Min	Typ	Max		
average transmission	70			%	7.5µm to 13.5µm
average transmission			1	%	visual to 5µm
cut on	5.2	5.5	5.8	µm	25°C
filter thickness		0.525			
filter material	silicon coated				

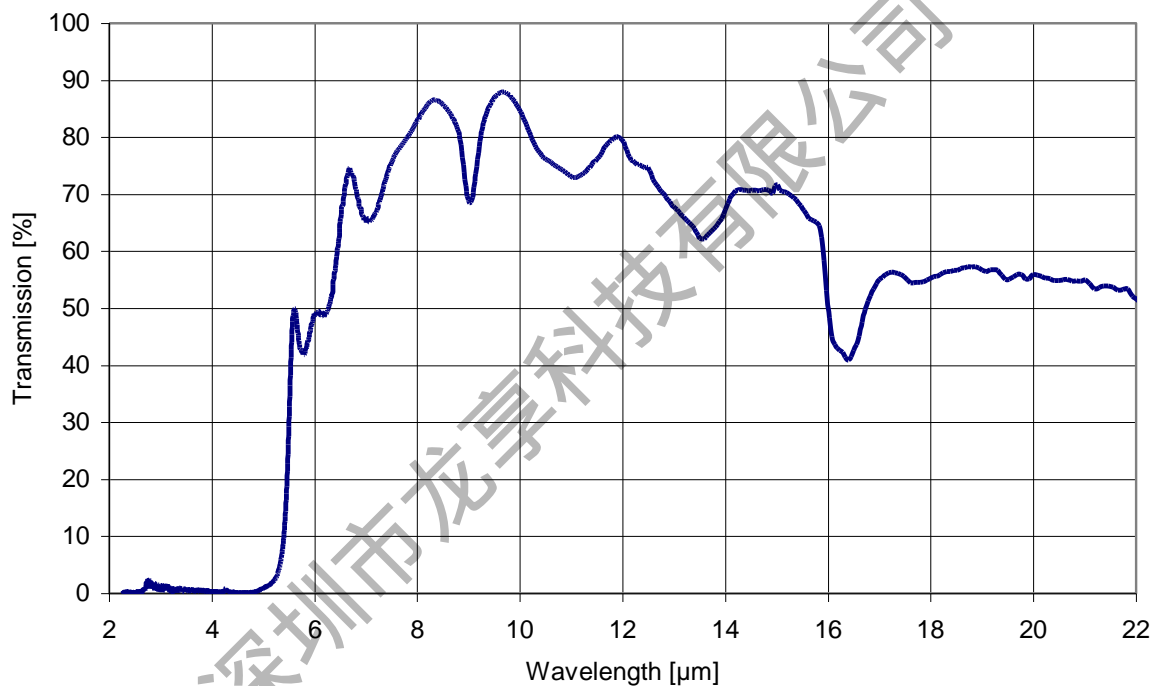

### 6. Field of View

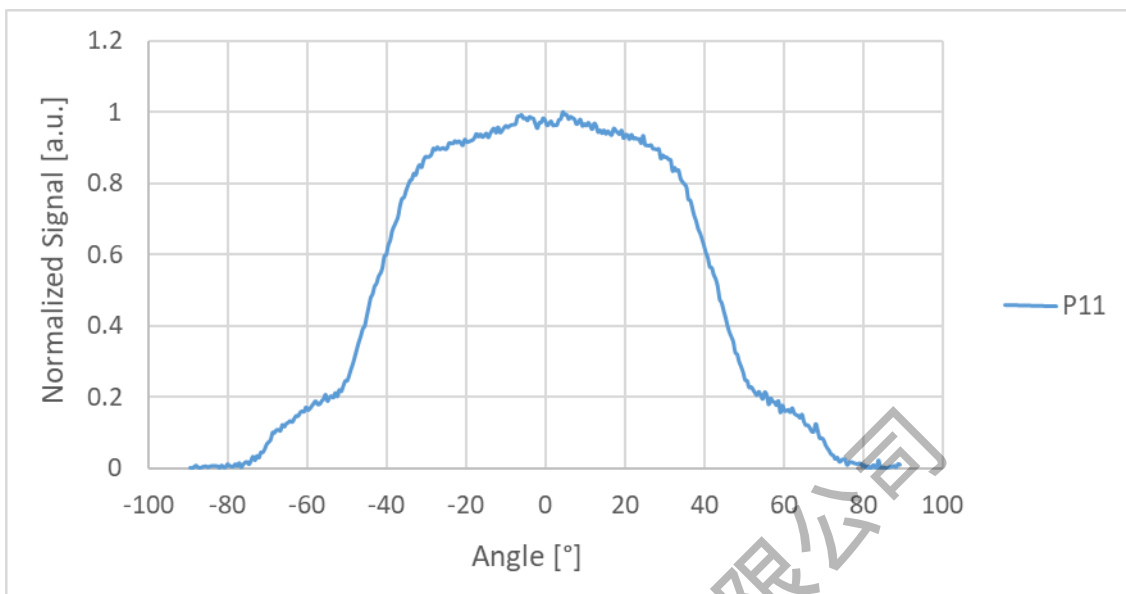

### 7. Heat Shock Response

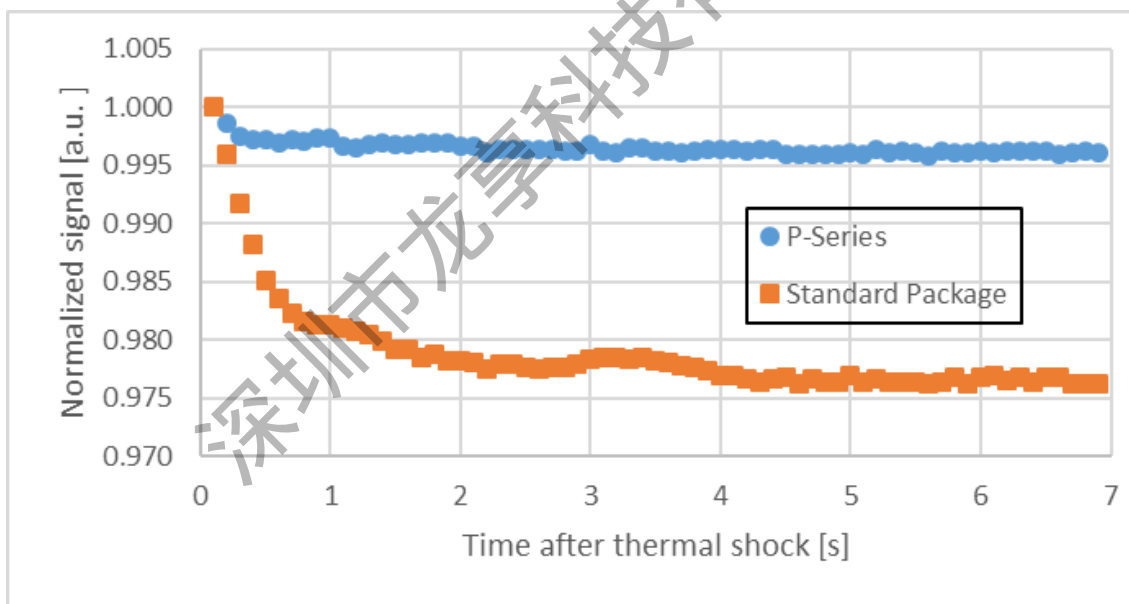

### 8. Drawing and Pin Assignment

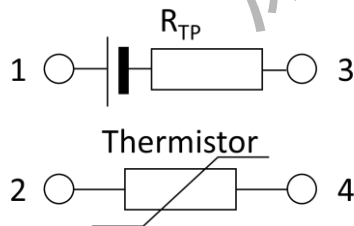
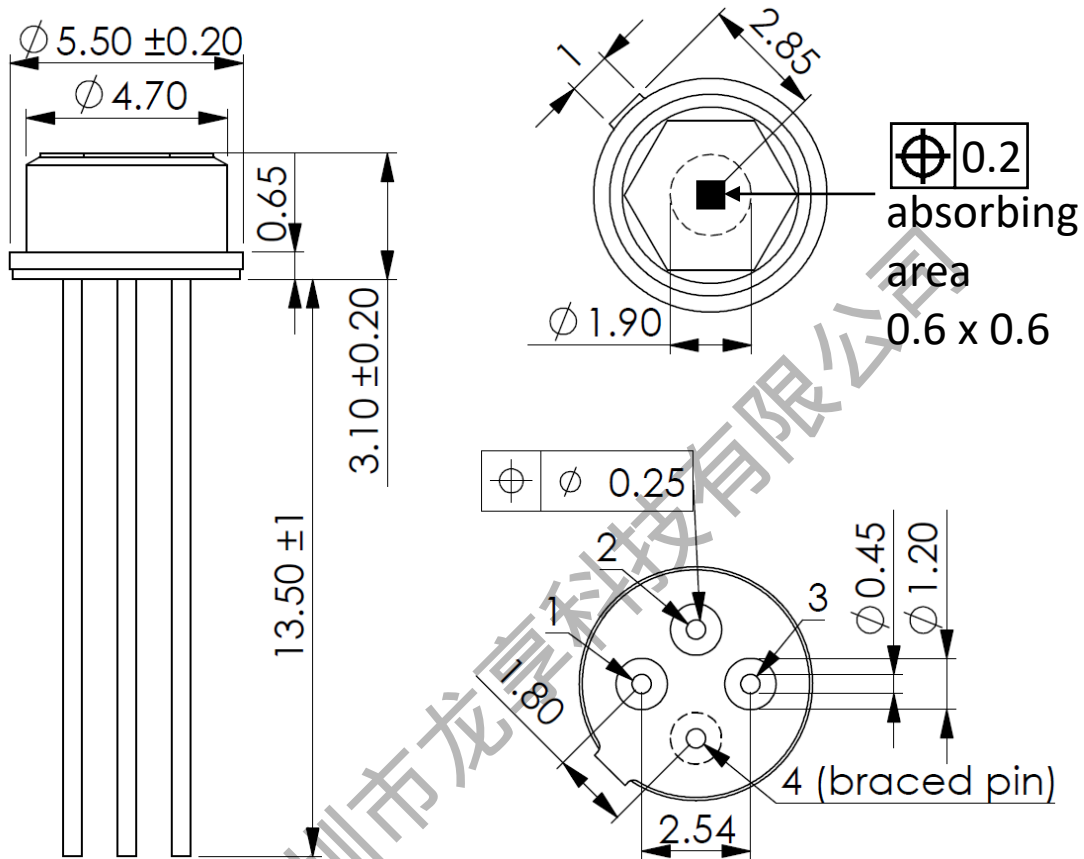

General Tolerance:  
DIN ISO 2768-m

<b>HEIMANN Sensor GmbH</b>		Product Specification: <b>Low Heat Shock Thermopile Sensor HMS P11 F5.5</b>
Author(s): E. Kersting	Rev.: R 01 / 13.12.2019	Page 7 of 7

## 9. General Directions for Further Processing

Stresses above the absolute maximum ratings may cause damages to the device. The sensor can be damaged by electrostatic discharges. Please take appropriate precautions for the handling.

Do not expose the sensors to aggressive detergents. Windows may be cleaned with alcohol and cotton swab.

Hand soldering and / or wave soldering may be applied by a maximum temperature of 280°C for a dwell time less than 10s. Avoid heat exposure to the top and the window of the detector. Reflow soldering is not recommended. The minimum distance between the housing body and the liquid solder should be at least 0.6mm.

### Storage:

- 1) Parts are to be stored indoors in the original packing.
- 2) Storage Temperature should be from +5°C to +40°C Recommended: 20 to 30°C).
- 3) A maximum of 60% Relative Humidity (Recommended: 40 to 60% RH).

### Shelf Life:

Heimann Sensor recommends the properly stored components be used within one years of receipt to guarantee a good solderability.

## 10. Liability

Important product or process changes require a customer release. Changes or modifications at the product which haven't influence to the performance and/or quality of the device haven't to be announced to the customers in advance.

Customers are requested to consult with Heimann Sensor representatives before the use of Heimann Sensor products in special applications where failure or abnormal operation may directly affect human lives or cause physical injury or property damage. The company or their representatives will not be responsible for damage arising from such use without prior approval.